



Stand und Zukunft der Antriebstechnologie im KFZ

Markus Schermann / September 29th, 2022



BRP



BRP COMPANY OVERVIEW



A GLOBAL LEADER IN THE POWERSPORTS INDUSTRY

ESTABLISHED GLOBAL DISTRIBUTION NETWORK

4,275 dealers in over 120 countries

GLOBAL AND MODERN MANUFACTURING FOOTPRINT

12 facilities in 6 countries | Over 20,000 employees worldwide

INDUSTRY LEADER IN INNOVATION

Investing ~4.0% of revenues annually in research and development

ski-doo

SEA-DOO

can-am

LYNX

telwater

Manitou
PONTOON BOATS

ROTAX

ALUMA
Craft

pinion

DELIVERED STRONG PERFORMANCE

Revenues

CA\$ billions

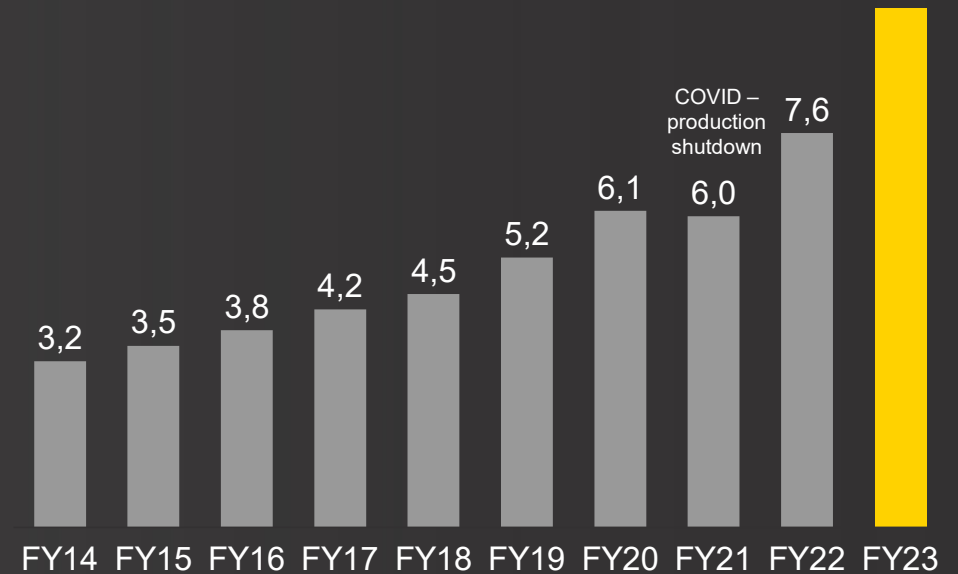

ESTABLISHED GLOBAL NETWORK



ESTABLISHED GLOBAL OPERATIONS

DEALERS

COUNTRIES

4,275

120+

WELL DIVERSIFIED GEOGRAPHIC SALES

USA

CANADA

INTERNATIONAL

56%

15%

29%

LEADING PRODUCT PORTFOLIO



REVENUES BY CATEGORY

YEAR-ROUND
PRODUCTS

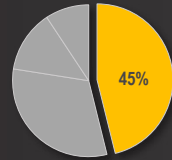

SEASONAL
PRODUCTS

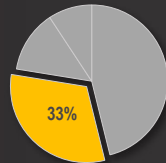

PA&A AND
OEM ENGINES

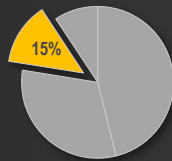

MARINE
PRODUCTS

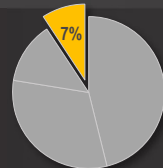

PRODUCT LINES



Extensive product portfolio of industry-leading brands providing multiple growth vectors

CAN-AM MOTORCYCLE



PINION – E-BIKE ANTRIEBE



BRP-ROTAX



Gunskirchen
Austria

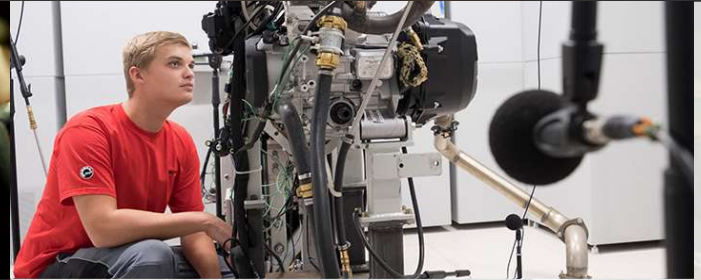

Facts & Figures

- BRP's powertrain division
- World's largest piston aircraft engine producer
- 1,700 employees
- 92,990 m²
- Revenue: 980 Mio. EUR (FY22)

Powertrains ICE & E-DRIVE

- Ski-Doo® und Lynx® snowmobiles
- Sea-Doo® Watercraft
- Can-Am® ATV, SSV
- Can-Am® Spyder, Ryker
- Karts
- Sport aircraft

Core competences

- Design
- Development
- Industrialization
- Manufacturing of complete powertrains ICE + EV
- Service



Austria

ENERGY IS LIMITED



- SUN LIGHT
- WIND
- HYDRO



ENERGY IS LIMITED



➤ FOSSILE

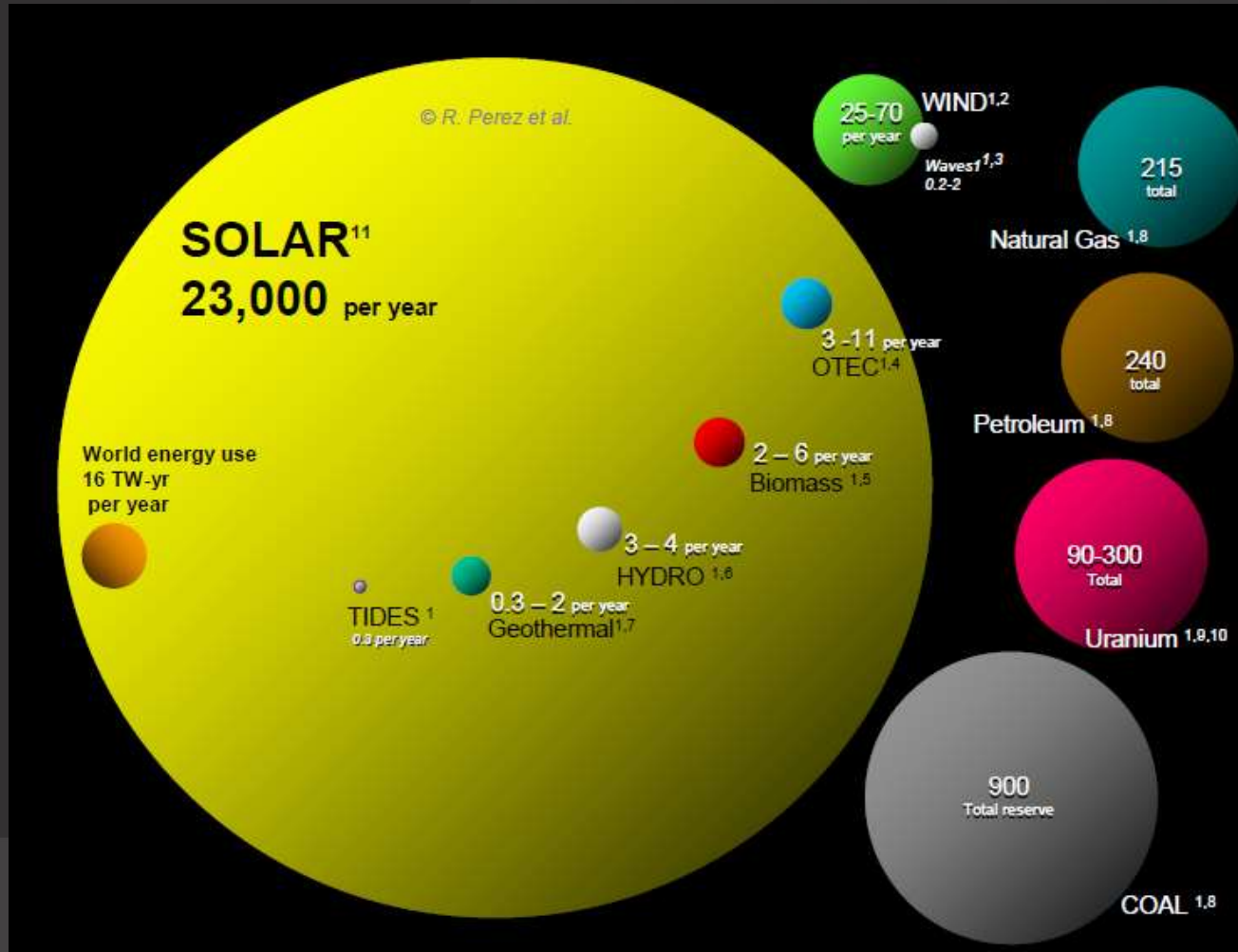

1 TWy=8740 TWh

<https://www.solarify.eu>

IT IS ALL ABOUT EFFICIENCY



- Wie viel Energie brauche ich, um meine Wohnung zu heizen?
- Wie viel Energie brauche ich, um von A nach B zu fahren?

Energie = Leistung * Zeit

$$10\text{kWh} = 1\text{kW} * 10\text{h}$$

FAHRZEUGE WERDEN EFFIZIENTER



$$F_w = c_w \cdot \rho \cdot A \cdot \frac{v^2}{2}$$

ANTRIEBE WERDEN EFFIZIENTER

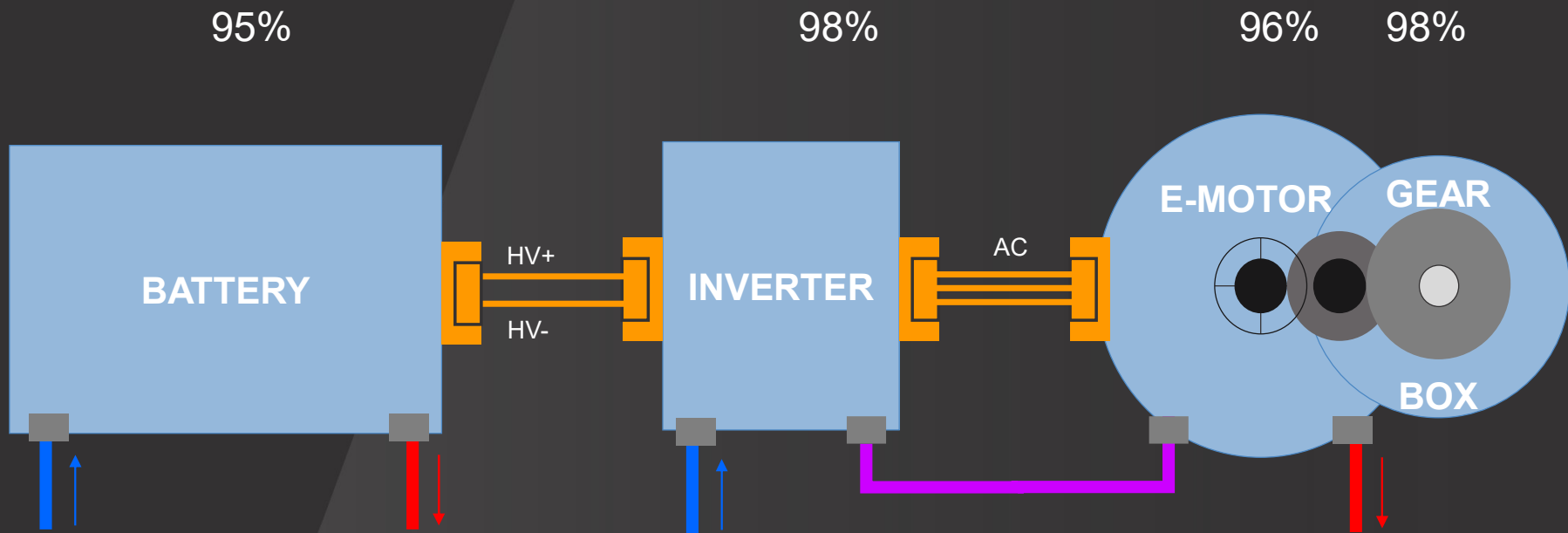

HOCHEFFIZIENTER PKW ANTRIEB

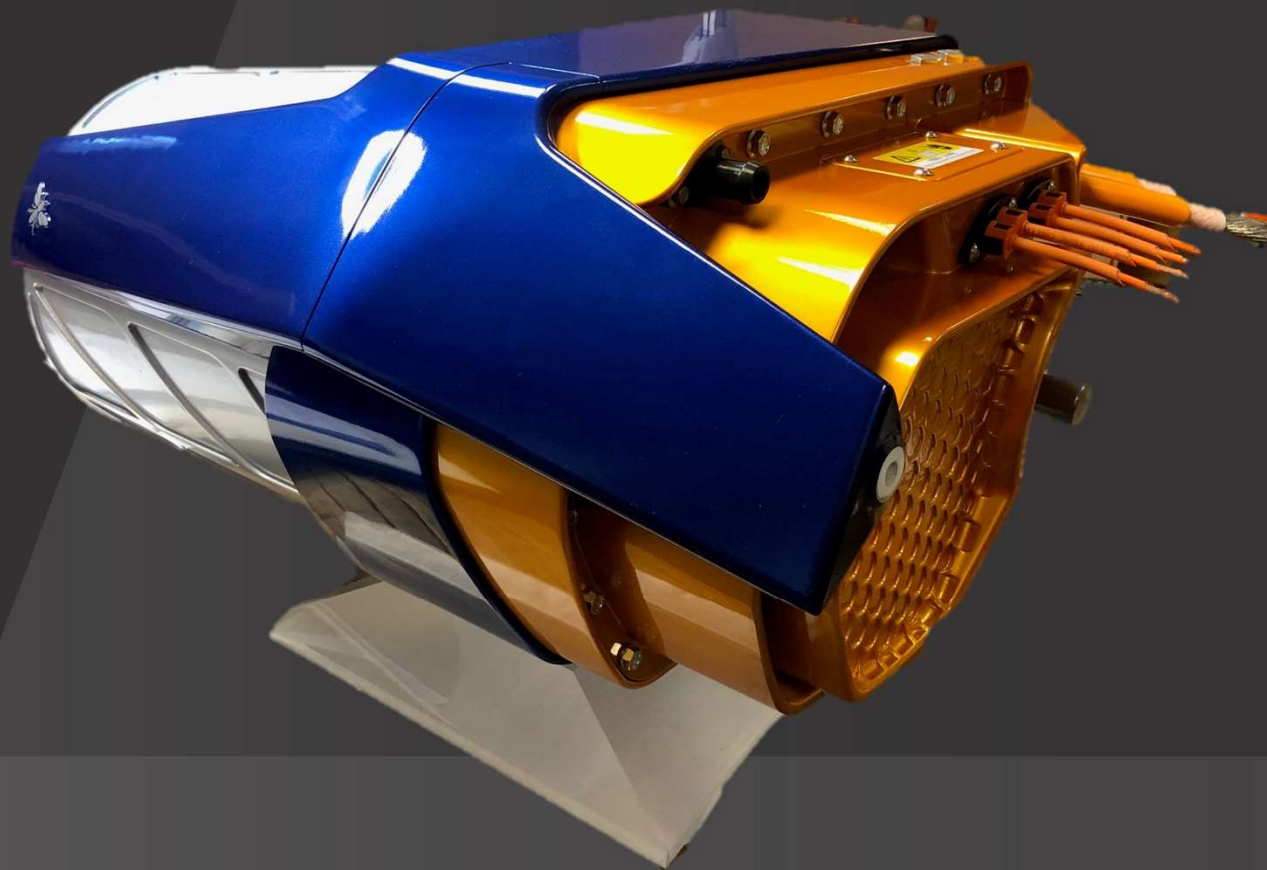

BATTERIE AUSBLICK



- Stetige Verbesserungen
- Festkörperbatterie
 - Potential bis zu 50% mehr Kapazität ohne Volumenvergrößerung bis zu 800Wh/Liter
 - Sicherheit, Rohstoffkosten, Großserienfertigung, Alterung, Langlebigkeit, Schnellladefähigkeit noch nicht erreicht
 - Sicherheitsvorteil nicht so groß wie erhofft
 - ab 2026 in Serie



BATTERIE EVOLUTION

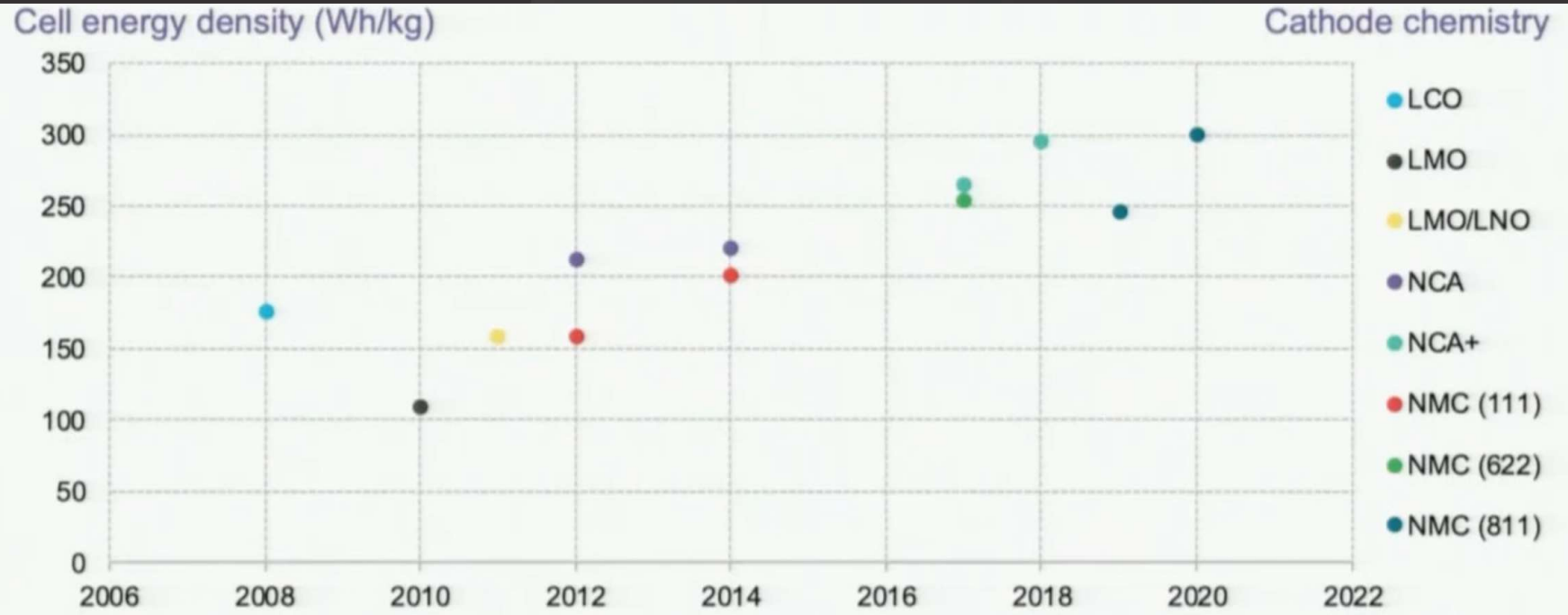

Source: BNEF, company reports

BloombergNEF

LADE-INFRASTRUKTUR HINKT NACH



Aktuelles Ausbautempo in der EU und erwarteter Bedarf der Ladeinfrastruktur

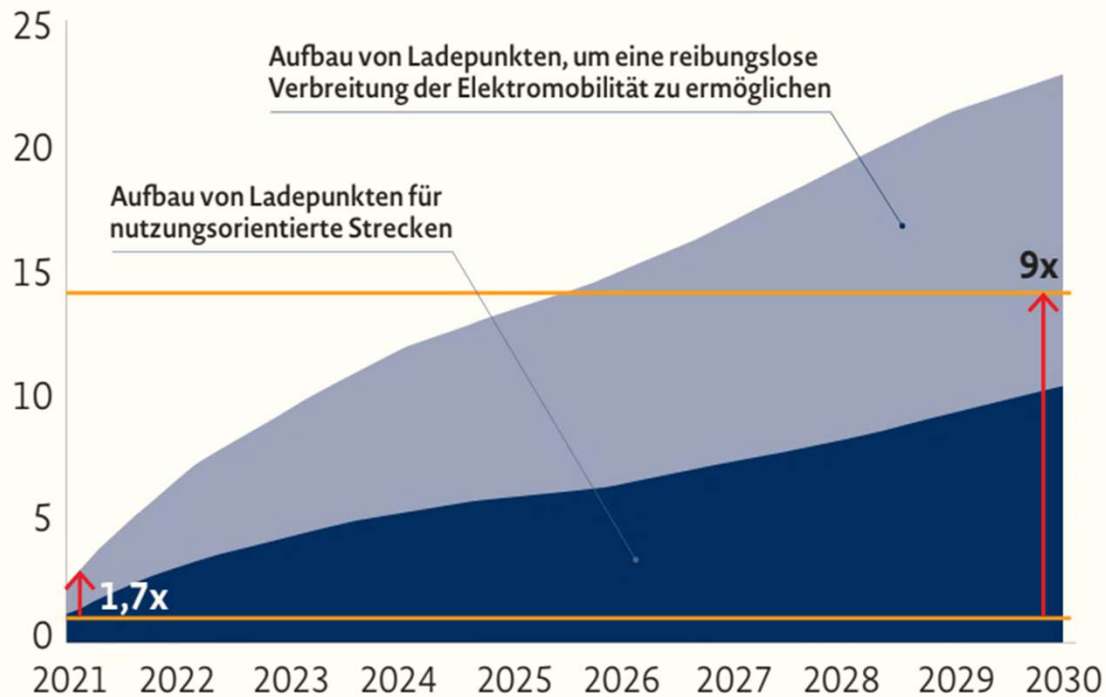

14.000
neue Ladepunkte
pro Woche in
Europa bis 2030
erforderlich

2.000
neue Ladepunkte
pro Woche in
Europa aktuell

Quelle: Masterplan, ACEA, März 2022

© Automobilwoche

Strombedarf in der EU durch Ladestationen bis 2030 in Terawattstunden

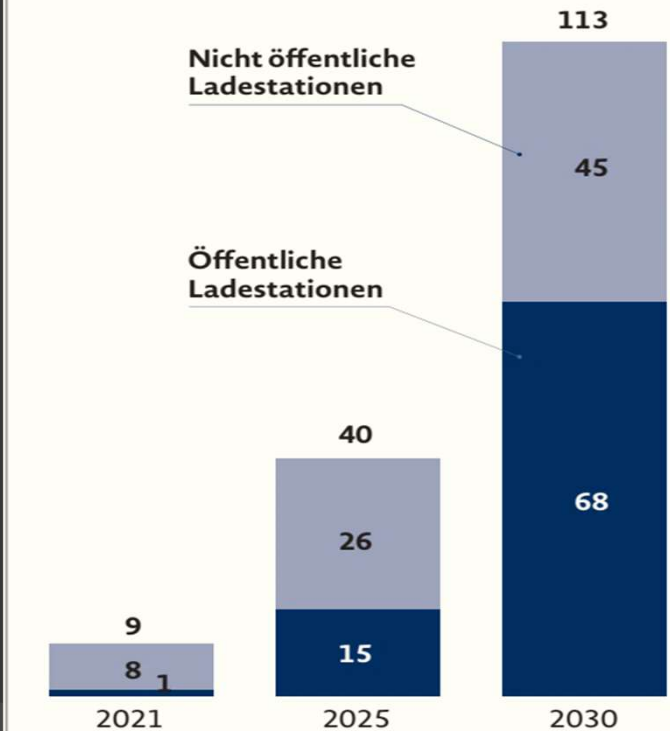

Quelle: Masterplan, ACEA, März 2022

© Automobilwoche

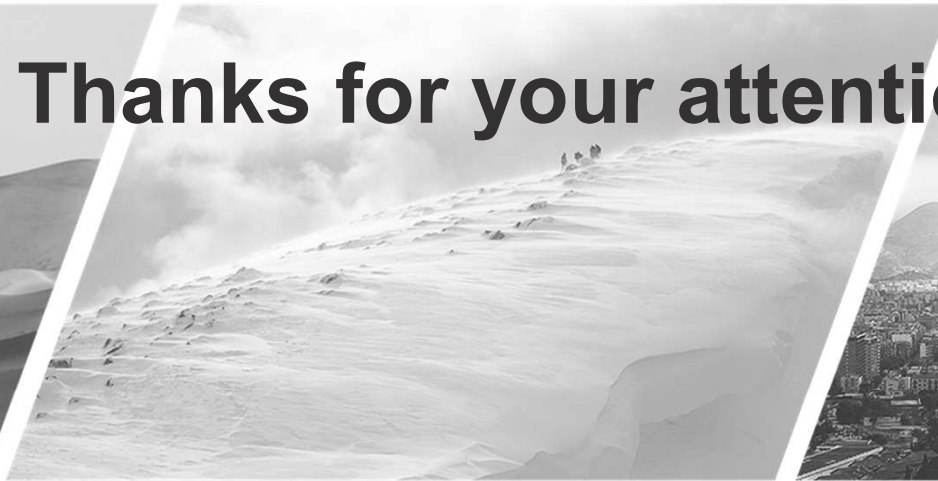
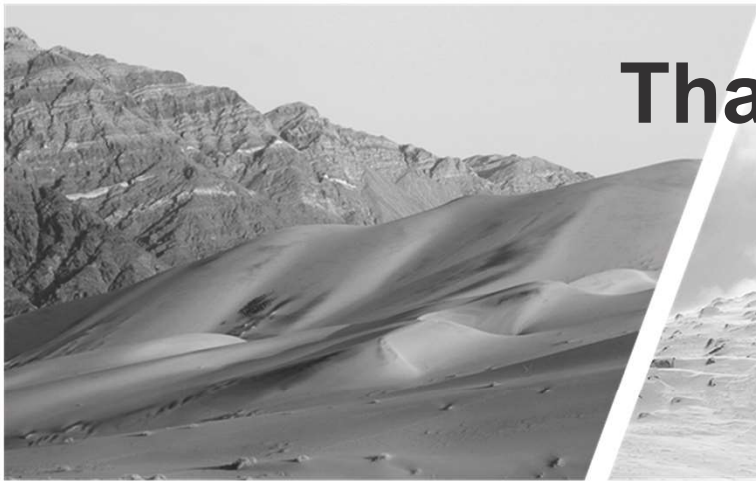

Thanks for your attention !



ski-doo LYNX SEA-DOO EVINRUDE ROTAX can-am